

DMA 8000

Dynamic Mechanical Analyzer

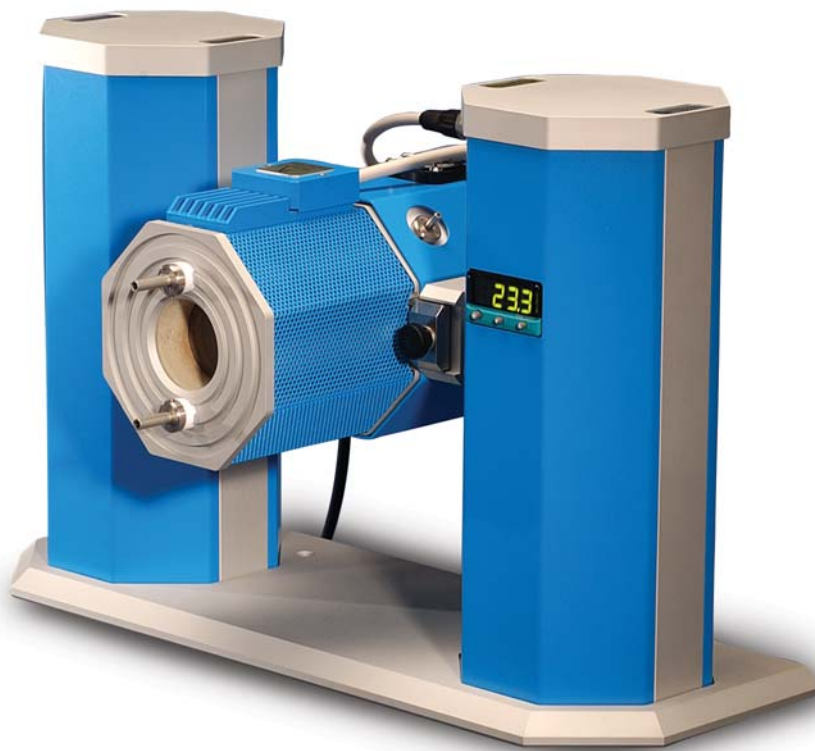

innovation in materials science

introducing the DMA 8000

Quick Glance:

- ▶ Unparalleled flexibility with rotating analysis head
- ▶ Enhanced performance due to a lightweight analytical train
- ▶ TMA capability
- ▶ Superior cooling design
- ▶ Integrated fluid bath option
- ▶ Controlled humidity studies with a unique humidity generator
- ▶ Optional furnace window for viewing the sample
- ▶ Analysis of powders or other difficult to prepare samples

Dynamic Mechanical Analysis (DMA) is widely used to characterize materials' bulk properties such as modulus, compliance, and damping (tan delta).

It measures changes of rheological behavior under dynamic conditions as a function of temperature, time, frequency, stress, atmosphere or a combination of these parameters.

Stress-strain, creep recovery or thermomechanical measurements are just a few examples of the uses of DMA.

The PerkinElmer® DMA 8000 is one of the most flexible, cost effective Dynamic Mechanical Analyzers available today.

Its innovative design, high functionality and flexible operation make the DMA 8000 ideal for advanced

research and routine quality testing. The flexibility arises from a number of powerful accessories that are available. For handling a wide range of samples, multiple geometry configurations are offered. Other options allow performance of UV curing tests, visually monitoring and/or recording samples during experiments, precise control of the humidity and temperature of a sample as its properties are studied, and immersing a sample in a fluid during testing. With the smallest footprint in the industry, the instrument reduces laboratory space requirements while operating on a standard laboratory bench.

The exceptional design, unconstrained by existing DMA approaches, was rewarded in 2001 with an R&D 100 Innovation Award for its advancement.

Innovation

Rotating analysis head

One of the most unique and useful features of the DMA 8000 is its rotating analysis head, which can be oriented through a full 180°. Unlike traditional DMA's, which have a single, fixed configuration, this rotational design essentially permits the DMA 8000 to be configured in the best possible orientation. Benefits include:

- Easy access to, and mounting of, samples
- Rapid changing of samples and clamps (typically less than 2 minutes)
- Immersion experiments in any geometry
- Optimal analysis head configuration for virtually any test type and sample geometry:

Geometry	Typical Orientation
3-Point Bending	Vertically up
Cantilever	Horizontal
Tension/Compression	Vertically up/down
Shear	Any orientation

the ultimate in design and innovation

Lightweight drive and clamp system

The novel lightweight analytical train incorporated in the DMA 8000 has minimal compliance and requires no stabilizing springs or air-bearing. Due to the patented design, no shaft support system is required, in contrast to most other DMA instruments, which require air or spring bearings. This design offers several advantages for the working laboratory:

- Enhanced performance since the drive system compliance does not significantly contribute to the measurement
- No risk of damage to the instrument associated with dirty or damp air
- No requirement for compressed air, hence no compressor to maintain
- High sensitivity due to low mass, yet very rigid titanium drive components
- Low maintenance due to inherent simplicity and chemically inert materials

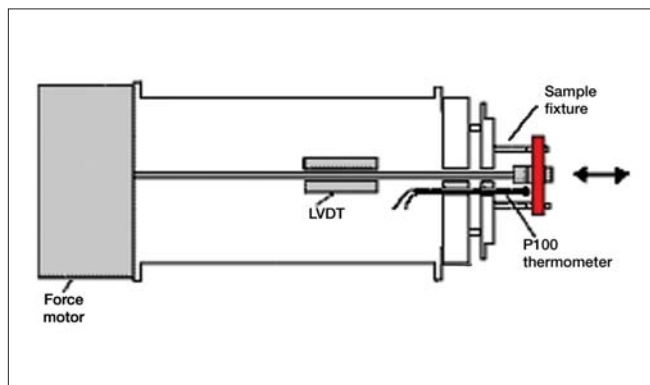

Figure 1. Light weight drive system

Unmatched cooling capability

Because low temperature operation is so important in mechanical testing, the DMA 8000 was designed with an ultra-efficient cooling system. In normal operation the instrument can cool both rapidly and with a minimum of liquid nitrogen, providing industry-leading performance.

The ability to cool down to -190 °C without immersion is exceptional and particularly important because most beta and gamma relaxation processes occur at ultra low temperatures.

The speed of cooling, or cool down time, is vital for high sample throughput and in laboratories where reduced liquid nitrogen consumption is important.

Start Temperature	Cool down Time from RT	LN2 Usage
-100 °C	5 minutes	~ 0.3 Liter
-150 °C	10 minutes	< 1 Liter
-190 °C	15 minutes	~ 1 Liter

The cooling system utilizes a low-pressure liquid nitrogen vessel for simple, convenient operation.

For many laboratories the 1L Dewar is the most simple and convenient system. Quickly pressurized, it offers rapid, safe use and its convenient size can be accommodated in many laboratories.

Larger Dewar sizes are also available for storage of larger quantities of liquid nitrogen, needed for prolonged experiments or multiple experiments without refilling. All cooling systems can be equipped with an Autocryo accessory for fully automated unattended operation.

unparalleled flexibility to accommodate various sample types

Analysis of powders, gels, and natural products

Our Material Pockets are a unique sample preparation tool specifically designed to work with the DMA 8000. These innovative pockets allow powdered or non-self supported materials, such as powdered drugs, gels, natural products like tea, coffee, herbs, etc. and low viscosity materials, to be investigated by DMA. Applications include detecting small amounts of amorphous material in samples that cannot be formed into a bar or a material naturally occurring in a powder-like state. They can also be used by creating a film or coating on the inside surface to allow the film to be studied easily. This is especially useful for extremely fragile, thin or "sticky" films. An example would be the curing of a cyanoacrylate adhesive.

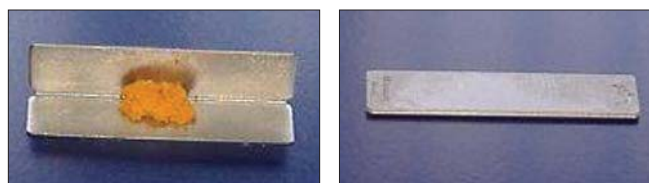

Material Pocket

Material Pockets are used in a bending mode geometry. Multi-frequency analysis reveals the character of any observed transition; the amorphous Tg response will be frequency dependant, whereas melting or chemical degradation will be independent of frequency.



Watch your samples

The standard furnace of the DMA 8000 is configured with a quartz window which provides a number of useful capabilities. The window allows visual inspection of the sample and clamping system throughout the experiment without interrupting the temperature profile or other experimental conditions. It also allows video recording of the sample during an experiment, which can provide useful information when later analyzing data.

Irradiate your samples

The quartz window furnace also allows UV/Vis irradiation for curing and other studies. A special shear clamping design offers unique capabilities for these studies. These measurements are also possible in tension. DMA investigations into the behavior of photo-curing and photo-reactive systems have never been easier.

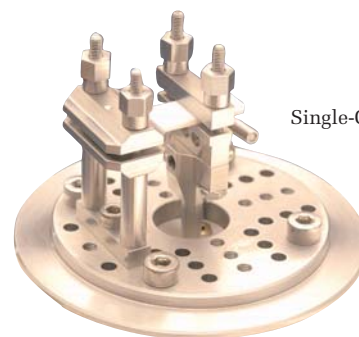

Single-Cantilever fixture

Flexibility

Geometry options

There are six common geometry modes that can be used for performing DMA experiments, covering the full range of sample testing needs. The geometry selected for an experiment is dictated by the nature and size of the sample being analyzed as well as its intended use. The fixtures can easily be adjusted to a variety of sample sizes.

Single Cantilever Bending mode is excellent for general characterization of most polymeric bar samples above and below their T_g. This mode is also ideal for examining powdered or flaked materials in the Material Pockets.

Dual Cantilever Bending mode is useful for low stiffness samples, such as thin films, using a small free length.

Tension mode is very useful for the analysis of thin films and fibers or can be used for bar samples with no static force if expansion information is required.

Compression mode is used with polymer foams, gels and natural materials such as bread dough, meat and

confectionery. It is also used for performing constant force (TMA) experiments.

Shear mode is useful if examining low stiffness materials such as elastomers, pressure sensitive adhesives, asphalts, bitumen, and tars, or studying the cure of materials such as epoxy resins.

3-Point Bending mode is used for accurate modulus work on stiff samples, e.g. composites or thermoplastics below their T_g and for cured thermosets. This mode's ease of loading makes it especially useful for quality control applications.

Single Cantilever Bending

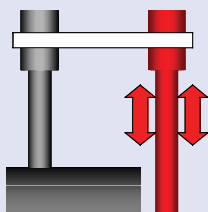

The sample is anchored on one end by a fixed clamp and by the drive shaft on the other. Bending stress is applied by the motor.

Dual Cantilever Bending

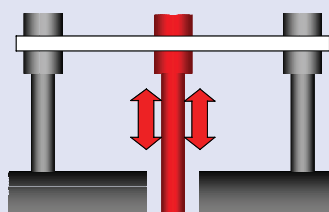

The sample is anchored on both ends by a fixed clamp and by the drive shaft at the mid point. Bending stress is applied by the motor.

Tension

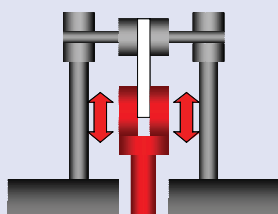

Sample is anchored on one end by a fixed clamp and by the drive shaft on the other. Tension stress is applied by the motor.

Compression

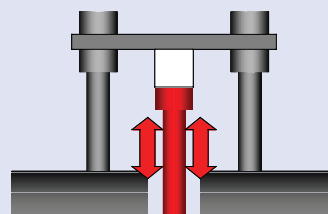

Sample is sandwiched between a fixed plate and a plate mounted on the drive shaft. Compression stress is applied by the motor.

Shear

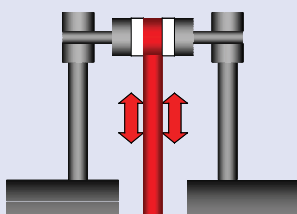

Two samples are sandwiched between two fixed plates and two plates mounted to either side of the drive shaft. Shear stress is applied by the motor.

3-Point Bending

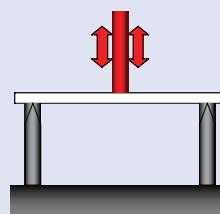

Sample is supported on both ends by a fixed bar and the drive shaft at the mid point. A bending stress is applied by the motor.

numerous experiments, one easy solution

Constant force (TMA) experiments

In addition to operation in dynamic mode, the DMA 8000 permits operation in a “constant force” vs. time or temperature (TMA) mode. Applications such as expansion coefficient, softening and penetration, or extension or contraction in tension geometry provide valuable data equivalent to many commercial stand-alone TMA instruments. The DMA 8000 provides a cost effective solution for various TMA applications, allowing DMA and TMA experiments on a single analyzer.

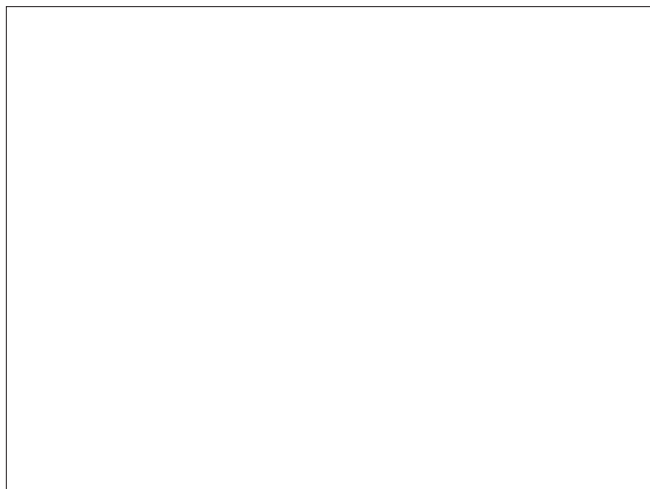

Immersion experiments

The DMA 8000 environmental fluid bath option has been designed as an integral part of the analyzer. The accessory allows true immersion studies on a sample while measuring the dynamic mechanical properties. All geometry modes are supported in immersion mode. The temperature range of the fluid bath is from subambient temperatures to 150 °C. A further unique capability

is that the low end temperature can be extended to -196 °C when liquid nitrogen is used as the immersion fluid. The immersion fluid can be temperature controlled by one of three methods:

- Using the built-in electrical heater control system
- Using a circulating fluid from a circulation bath or chiller
- Operation to -196°C when using liquid nitrogen as the immersion fluid



Controlled humidity experiments

The Humidity Generator and Controller is a powerful and flexible option which delivers the capability to apply and accurately control relative humidity to the sample environment in the DMA 8000. It offers an easy means of obtaining mechanical properties of materials under defined RH conditions.

The system operates by mixing and proportioning streams of dry and moist air. Direct feedback from a humidity sensor with close proximity to the sample provides a continuous means to monitor and control the exact humidity at the sample.



Humidity Controller

Features include:

- Unique "sample site" humidity feedback control
- Capability to vary the humidity level during the run
- Heated transfer line to avoid condensation
- DMA response plotted against humidity

Applications include:

- Moisture induced phase transitions
- Moisture sensitive materials like paper, natural fibers, and food products
- Swelling, shrinking and stiffness changes as humidity changes
- Plasticizing and Tg effects as seen in nylon and polyurethanes

Instrument control

Simple, powerful software

Operation of the DMA 8000 is through a powerful software program based on a Microsoft® Excel architecture. It offers a number of features and flexible options that include:

- Reprogramming during an experiment
- Full choice of parameters for live graphical and tabular output
- Constant update of data
 - No data loss if power interrupted
- Unique data collection through resonance
- Additional macros easily created
- Flexibility of parameters
 - Customized geometry constants
 - Total transparency of calculations
 - Chart Wizard

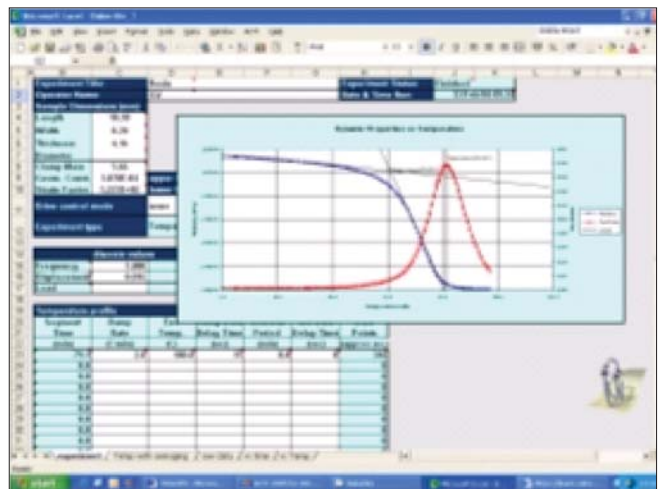

DMA Software

meeting your application needs

Thermal expansion of PC

The sample was mounted in the tension clamps of the DMA 8000. Data was collected from ambient to 140 °C. Figure 2 shows the sample displacement against temperature for a polycarbonate. The glassy region is plotted and the instrument expansion has been subtracted. The equation of the linear regression line gives an expansion coefficient of $1.7 \times 10^{-4} \text{K}^{-1}$ after the sample length has been accounted for.

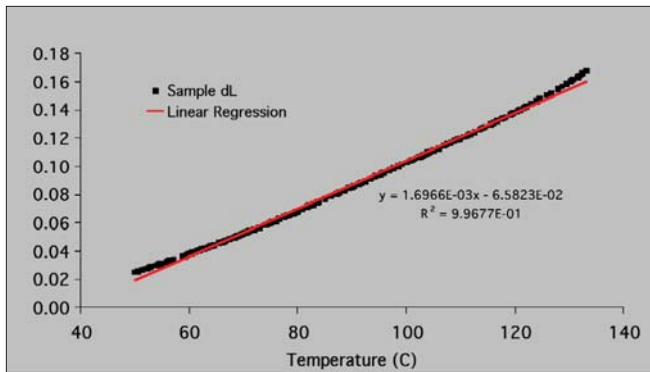

Figure 2: Sample displacement against temperature for a polycarbonate.

This example shows that the DMA 8000 can be used in “TMA mode” in order to determine expansion behavior of materials as a function of temperature. The expansion coefficient can be determined with ease.

Use of Material Pockets for mechanical analysis of powders

Polystyrene

Figure 3 shows $\tan \delta$ data from two DMA experiments with polystyrene. The original sample was the same, but the red line shows an experiment run with a bar sample in single cantilever bending and the black line shows an experiment run with grated polystyrene in a Material Pocket. Both were run at 1 Hz. It is clear that the glass transition, shown as a peak in the $\tan \delta$ data, is the same for both experiments. The peak value is less for the Material Pocket but this is a reflection of the lower sample mass. This experiment demonstrates that it is possible to use the Material Pocket to obtain relaxation data on a sample that the stainless steel of the pocket is unaffected.

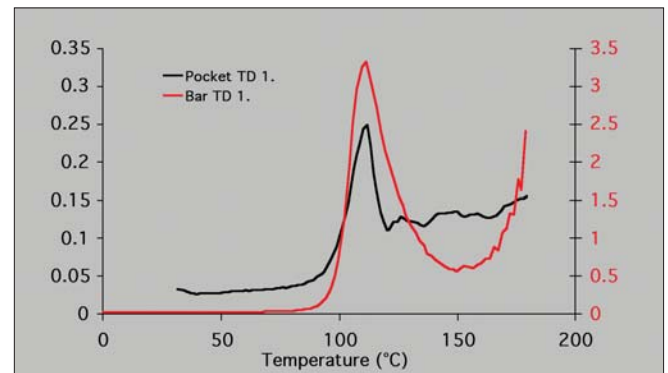
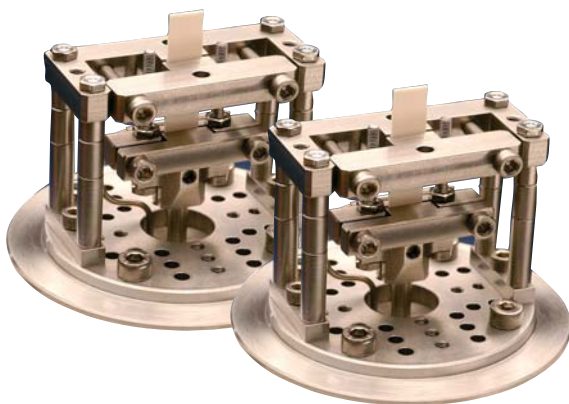

Figure 3: Tan δ for polystyrene.



Caption

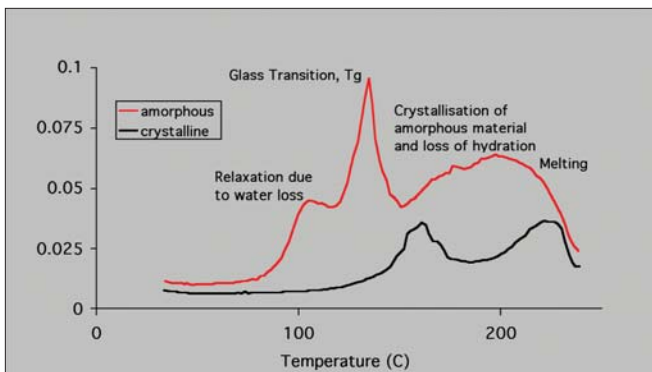

Figure 4: Tan δ for lactose.

Lactose

Tan δ data for two samples of lactose are shown in Figure 4. The red line is for 100% lactose amorphous and the black line for 100% crystalline. Amorphous lactose is more hygroscopic than crystalline lactose, hence, there is a peak in the graph at around 100 °C corresponding to latent water being driven off. A glass transition is observed in the amorphous sample then an event corresponding to recrystallization of the amorphous material. Also under this event is a loss of hydration water which shows in the crystalline sample as well. As the temperature is increased further, the sample begins to melt.



Multifrequency analysis of Epoxy-based PCB (Printed Circuit Board)

The sample was mounted in the 3-point bending clamps and cooled to -150 °C prior to starting the DMA experiment. The measurement was run with a heating rate of 3 °C/min.

Figure 5 shows the glass transition of this sample as a peak in the tan δ and a drop in modulus. A clear frequency dependence is seen confirming the transition as a relaxation. The modulus of the material before and after this transition is relatively constant at approximately 2.3×10^{10} and 5.0×10^9 Pa respectively. The glass transition temperature, as defined by the peak in the tan δ , is shown to be between 142.6 °C and 151.8 °C depending on the frequency.

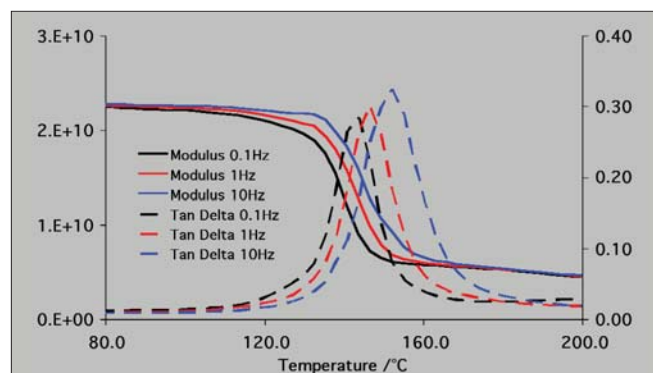

Figure 5: Glass transition.

DMA 8000 specifications

Rotating Analysis Head:	<ul style="list-style-type: none"> Vertically up (forward) and 45° in between these positions Vertically down Horizontal 																								
Temperature Range:	Standard furnace -190 °C to 400 °C High temperature furnace -190 °C to 600 °C Immersion bath -196 °C to 150 °C																								
Scanning Rates	Heating rate 0 °C to 20 °C/min* (standard furnace) Cooling rate 0 °C to 40 °C/min* (standard furnace) * at mid range (100 °C), may not be achieved at elevated temperatures																								
Liquid Nitrogen Coolant Consumption:	<table> <tr> <td>-100 °C</td> <td>5 minutes</td> <td>0.3 LN₂</td> </tr> <tr> <td>-150 °C</td> <td>10 minutes</td> <td><1 LN₂</td> </tr> <tr> <td>-190 °C</td> <td>15 minutes</td> <td><1 LN₂</td> </tr> </table>	-100 °C	5 minutes	0.3 LN ₂	-150 °C	10 minutes	<1 LN ₂	-190 °C	15 minutes	<1 LN ₂															
-100 °C	5 minutes	0.3 LN ₂																							
-150 °C	10 minutes	<1 LN ₂																							
-190 °C	15 minutes	<1 LN ₂																							
Frequency:	Range 0 to 300 Hz (depends on sample) Max. number up to 100 per experiment Resolution 0.001 Hz																								
Dynamic Displacement:	0 to ±1000 µm																								
Stiffness Range:	2 x 10 ² to 1 x 10 ⁸ N/m resolution 2 N/m																								
Modulus:	Resolution 0.0001 Pa Range ~10 ³ to 10 ¹⁶ Pa																								
Tan Delta:	Resolution 0.00001																								
Force:	Range ±10 N Minimum 0.002 N Resolution 0.002 N																								
Displacement/Strain	Resolution 1 nm Range +/- 1000 µm																								
Sample Size:	Maximum 52.5 mm x 12.8 mm x 8.0 mm																								
Geometry Options:	<table> <thead> <tr> <th>Mode</th> <th>Options</th> <th>Range</th> </tr> </thead> <tbody> <tr> <td>Single Cantilever Bending</td> <td>18</td> <td>1.0 – 17.5 mm</td> </tr> <tr> <td>Dual Cantilever Bending</td> <td>18</td> <td>2.0 – 35.0 mm</td> </tr> <tr> <td>3-Point Bending</td> <td>6</td> <td>20.0 – 45.0 mm</td> </tr> <tr> <td>Tension</td> <td>unlimited</td> <td><10 mm</td> </tr> <tr> <td>Compression</td> <td>unlimited</td> <td><10 mm</td> </tr> <tr> <td>Shear</td> <td>10 mm diameter plate</td> <td></td> </tr> <tr> <td>Material Pockets</td> <td>powders/non self supporting samples</td> <td></td> </tr> </tbody> </table>	Mode	Options	Range	Single Cantilever Bending	18	1.0 – 17.5 mm	Dual Cantilever Bending	18	2.0 – 35.0 mm	3-Point Bending	6	20.0 – 45.0 mm	Tension	unlimited	<10 mm	Compression	unlimited	<10 mm	Shear	10 mm diameter plate		Material Pockets	powders/non self supporting samples	
Mode	Options	Range																							
Single Cantilever Bending	18	1.0 – 17.5 mm																							
Dual Cantilever Bending	18	2.0 – 35.0 mm																							
3-Point Bending	6	20.0 – 45.0 mm																							
Tension	unlimited	<10 mm																							
Compression	unlimited	<10 mm																							
Shear	10 mm diameter plate																								
Material Pockets	powders/non self supporting samples																								
TMA Mode	Measurement range ±1000 µm Geometry tension and compression Sensitivity 10 nM Force load min/max 0.002 N / +/- 10 N Sample size up to 10 mm																								
Atmosphere	Static; controlled flow with air or inert gas; fluid (immersion); humidity																								

OPTIONS:			
Fluid Bath:			
Temperature Range:	-196 °C to 150 °C (dependant on immersion fluid used) Optional K-type thermocouple available for accurate fluid temperature control		
Bath Material:	Standard PTFE coated Aluminium and optional Pyrex Glass		
Humidity Generator:	5% to 90% (25 °C)		
Humidity Range:	10% to 80% (80 °C)		
Temperature Range:	5 °C to 80 °C Care must be taken regarding dew points for low temperature studies		
Optical Windows:	Standard configuration with 400 °C furnace: quartz Optional lateral windows or apertures available		
Instrument Weight:	15 kg (33 lbs)		
Instrument Dimensions:	170 mm depth x 475 mm width x 340 mm height 6.7 in depth x 18.7 in width x 13.4 in height		
Connections:	Electrical	85 to 264 V AC, 600VA	
	Interface	1 USB input	
	Purge gas	4 mm purge gas inlet	
	Cryogenic fluids	6 mm inlet port	
Conformance:	Low voltage directive 73/23/EEC	EN60950	1992
	EMC directive 89/336/EEC	EN50081-1	1997
		EN50082-1	1998
	Conformity mark	CE	2000

**PerkinElmer Life and
Analytical Sciences**
710 Bridgeport Avenue
Shelton, CT 06484-4794 USA
Phone: (800) 762-4000 or
(+1) 203-925-4602
www.perkinelmer.com



For a complete listing of our global offices, visit www.perkinelmer.com/lasoffices

©2006 PerkinElmer, Inc. All rights reserved. The PerkinElmer logo and design are registered trademarks of PerkinElmer, Inc. Pyrex is a registered trademark of Corning, Inc. and Microsoft Excel is a registered trademark of Microsoft, Inc. All other trademarks not owned by PerkinElmer, Inc. or its subsidiaries that are depicted herein are the property of their respective owners. PerkinElmer reserves the right to change this document at any time without notice and disclaims liability for editorial, pictorial or typographical errors.