

# TGA 4000

## Thermogravimetric Analyzer

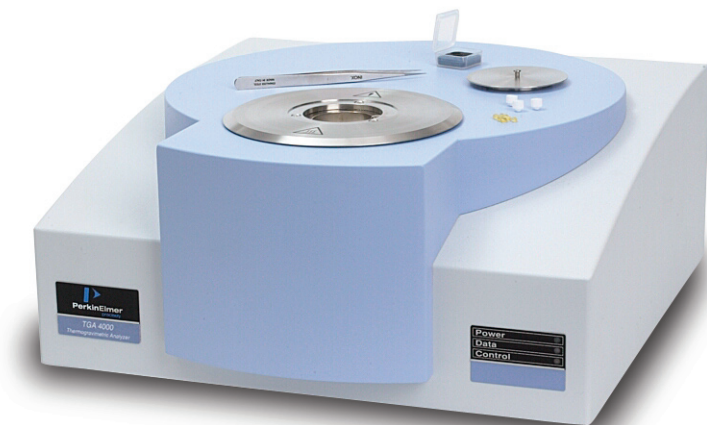

### Thermal analysis solutions and beyond

At PerkinElmer, we're committed to the future of thermal analysis. We prove it with our new TGA 4000, which delivers the answers you need with less effort than you ever thought possible. Whether you're researching new materials or ensuring the quality of your products, the TGA 4000 delivers great results, all day and every day.

### Fast, accurate, precise

Your success starts with our compact ceramic furnace, which provides the temperature control needed for accurate, precise results and the fast sample purge and cool down required for short cycle times. Forced air and liquid cooling further reduce cycle times allowing you to run more samples in less time. The ceramic construction is inert and corrosion resistant for improved ruggedness, permitting a wide range of reactive gases for enhanced applications flexibility. A large isothermal zone keeps your samples at the same temperature as the furnace throughout a temperature program providing you with results, even with large samples up to 1500 mg weight or 180  $\mu$ l volume.

### Key Features

- ▶ Compact footprint with optional autosampler
- ▶ High performance balance and furnace for maximum accuracy and precision
- ▶ Top loading balance for easy sample loading and unloading
- ▶ Furnace and balance isolated from operators to minimize maintenance, ensuring uptime
- ▶ Fast cooling reduces cycle times improving productivity
- ▶ Integrated mass flow controller extends applications flexibility
- ▶ Optional 45 position autosampler allows unattended operation, improving productivity
- ▶ Pyris software suite is easy to use and feature rich for maximum application flexibility

# TGA 4000 —

## Thermogravimetric Analyzer

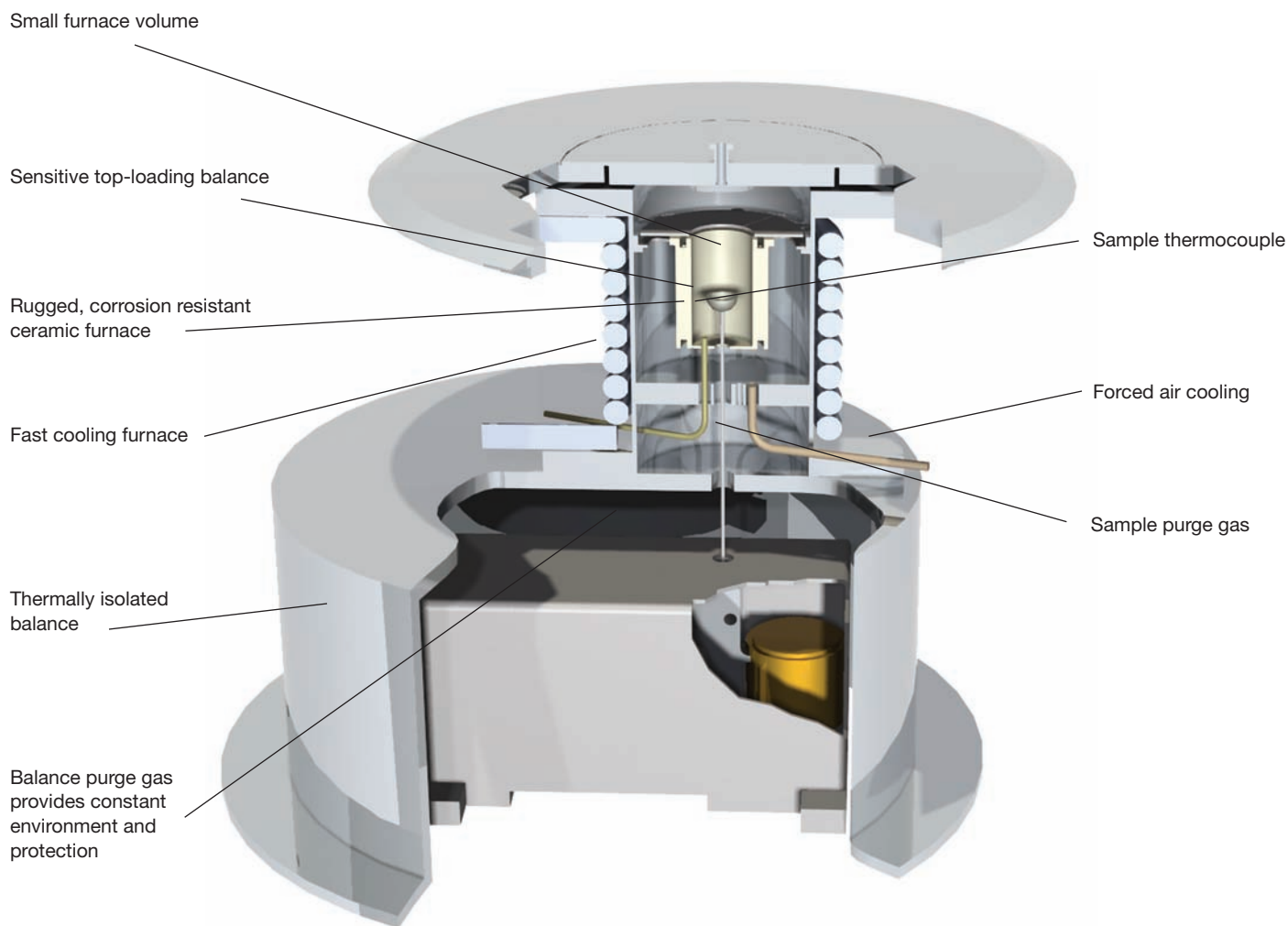

### Stable and robust

A sensitive and stable top loading balance makes it easy for anyone to load and unload samples. The balance is isolated from operators to protect it from damage, and protected from sample debris by an over pressure balance purge gas. Thick stainless steel walls act as a large heat sink thermally isolating the balance from the furnace, ensuring its stability.

### Flexible enough for all your applications

Many methods require specific gas flow rates and others may require switching during analysis. In both situations

the integrated mass flow controller monitors and controls purge flow rates and pressures, and can switch automatically between sample gases, all under Pyris™ software control. Other advantages include the ability to program a fast purge-out of residual oxygen or a quick oxidizing furnace clean up step at the end of a run. For even more flexibility the optional autosampler allows operators to sequence methods, each defining its own purge and sample gas conditions and gas switching points. Pyris software even prevents you from making mistakes, for example asking the autosampler to load two samples at a time or alerting you that a gas tank is empty.

## Reliable automation

To enhance sample throughput or simply make your TGA 4000 even easier to operate, select the optional high capacity 45-position autosampler. For ultimate productivity, a unique two piece carousel allows removal and reloading of one carousel section while the other keeps going. Sample changing reliability is a must for any autosampler and is also where the TGA 4000 excels. Patented (U.S. 6,203,760) gripper technology uses smart Shape Memory Alloy (SMA) to transfer your samples securely, every time. For the fastest cycle times, Pyris software monitors furnace temperature and automatically loads the next sample on cooling.

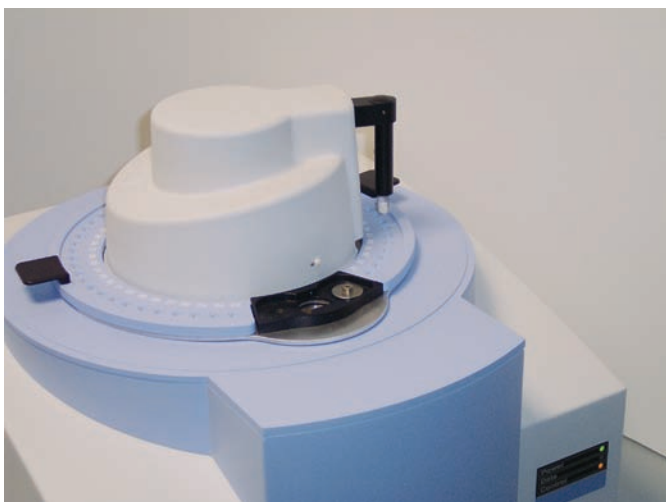

## The long-established software benchmark

Powerful, flexible and proven – the Pyris software combines simplicity and sophistication into a platform that crosses all Thermal Analysis technologies. With a broad range of options and products, your software capability can grow from simple, routine materials testing to advanced research software as your requirements demand.

## Thermogravimetric analysis application areas

- Sample Volatility
- Moisture Content
- Loss on Drying
- Oxidation Stability
- Decomposition Temperatures
- Filler Content
- Carbon Black Content
- Performance of Stabilizers
- Ash Content
- Catalyst and Coking Efficiency
- Product Stability
- Out-gas Analysis
- Flammability Studies

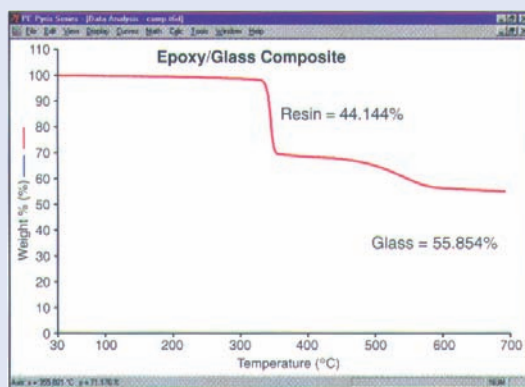

Figure 1. Physical properties of epoxy/glass composites are affected by the resin-to-glass ratios. Since glass is generally less expensive than resin, manufacturers strive to maximize glass content while maintaining the desired performance properties of the composite. The TGA 4000 is used to determine the percentage of resin and glass in the composite.

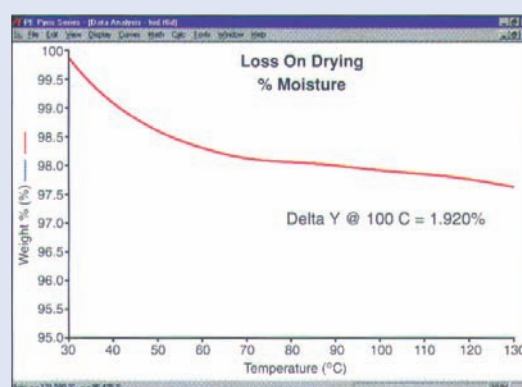
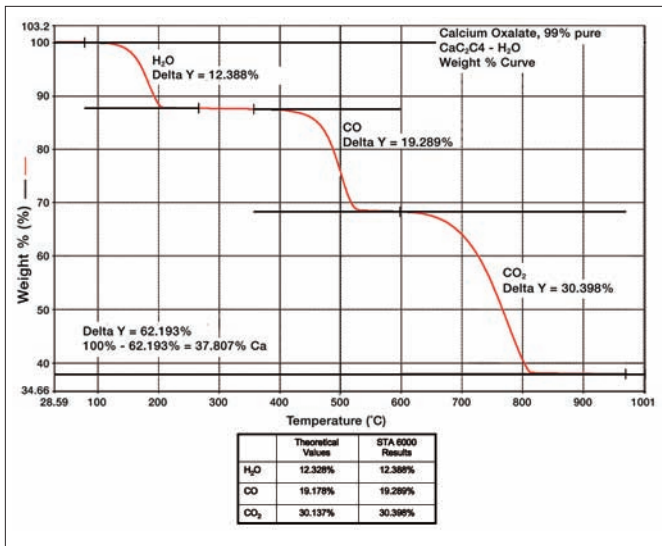

Figure 2. Drug quality and shelf life are directly affected by the volatile material content. Loss on drying values for water and solvents is routinely determined via simple heating experiments using the TGA 4000.

## Thermogravimetric (TG) verification

### Calcium Oxalate

Calcium oxalate is a well characterized material that has three distinct weight loss events that occur during heating: H<sub>2</sub>O, CO, CO<sub>2</sub>. To verify the performance of the TGA 4000, an experiment was conducted using 15 mg of calcium oxalate with a nitrogen purge gas. The samples were run using a scanning rate of 20 °C/minute. As you can see from the figure, the weight loss events recorded by the TGA 4000 are extremely comparable with the theoretical values of calcium oxalate.



## Low starting temperature

### Copper Sulfate Hydrate

Copper Sulfate (CuSO<sub>4</sub>) exists as a series of compounds which differ in regard to their degree of hydration. When hydrated forms are left at room temperature they begin to lose weight. In this example, the sample has been held at a starting temperature of 15 °C for 5 minutes before heating begins. Note the stability of the TG curve during this time.

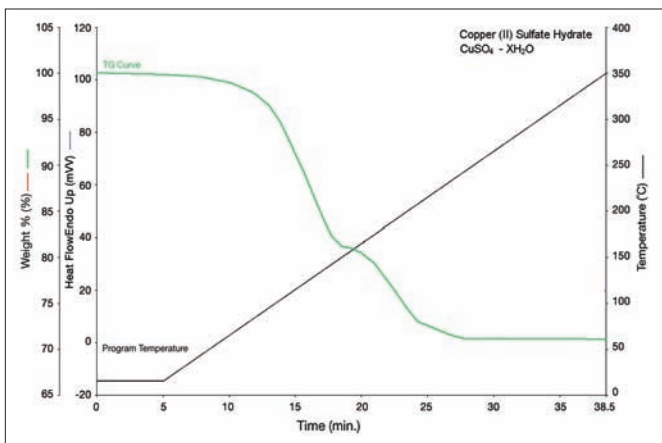

## Hyphenated techniques

### Calcium Oxalate

When studying the thermal degradation of polymers, coupling a thermogravimetric analyzer (TGA) with a mass spectrometer (MS) proves to be a valuable tool. Gases evolving from the sample as it is heated in a TGA can be identified by the MS. In this example, MS measurements are used to show the components of calcium oxalate eluting during the weight loss steps. Notice the order of magnitude difference between the H<sub>2</sub>O and CO<sub>2</sub> results compared to the CO results (x10<sup>2</sup>). This collection of MS data was captured using the Pyris software.

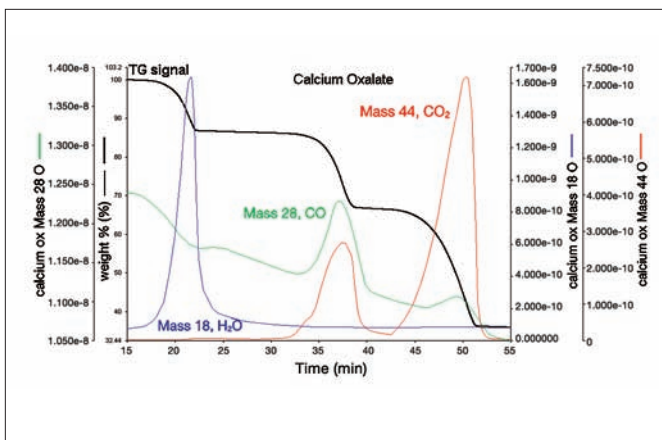

## Hyphenation capabilities

Do you want to get a better understanding of the chemical composition of your evolved sample gas? If you answered yes, we have the perfect solution for you. PerkinElmer allows you to seamlessly interface your PerkinElmer TGA to a PerkinElmer FT-IR, Mass Spectrometer or GC/MS. The gas line interfaces are optimized for PerkinElmer instruments with complete systems supported by our global service network ensuring your security and confidence. PerkinElmer channel partners provide additional interfaces should you need to connect to a detection device from a different manufacturer.

## A complete suite of Thermal Analysis solutions

PerkinElmer has been driving thermal analysis innovation for more than 40 years and has a highly developed portfolio of solutions including:

- Research grade TGA: Pyris 1
- TG-DSC: STA 6000
- Family of heat flux, power compensation and HyperDSCs: DSC 4000, 6000, 8000, 8500
- DMA: DMA 8000

In addition, access [www.perkinelmer.com/supplies](http://www.perkinelmer.com/supplies) for our comprehensive range of accessories and consumables that are available at great prices and in most cases available for immediate delivery.

## Uptime and longevity for your new investment

PerkinElmer prides itself on providing you with world class service and support. With over 1300 PerkinElmer employed service engineers in more than 40 countries, you can be confident of a fast response regardless of your geography.

Globally harmonized engineer training programs ensure consistently high technical standards, improving fix rates and instrument uptime. Our service regions support multiple technologies, making us the only provider who can support your hyphenated systems.

If system uptime, performance and low cost of ownership are important to you then PerkinElmer is your number one choice.

A range of services are offered to meet the challenges of various environments and working practices

- On demand service
- Service plans to cover repairs and/or preventive maintenance
- Training on instruments or applications
- Qualification using standard PerkinElmer protocols
- Creation, validation and implementation of custom qualification and validation documentation
- Instrument and complete lab relocations



TGA 4000 – Spectrum 100 TG-FT-IR  
with TL-8000 Transfer Line

**PerkinElmer, Inc.**  
940 Winter Street  
Waltham, MA 02451 USA  
Phone: (800) 762-4000 or  
(+1) 203-925-4602  
[www.perkinelmer.com](http://www.perkinelmer.com)



---

For a complete listing of our global offices, visit [www.perkinelmer.com/ContactUS](http://www.perkinelmer.com/ContactUS)

©2009 PerkinElmer, Inc. All rights reserved. The PerkinElmer logo and design are registered trademarks of PerkinElmer, Inc. Pyris and Spectrum are trademarks of PerkinElmer, Inc. or its subsidiaries, in the United States and other countries. All other trademarks not owned by PerkinElmer, Inc. or its subsidiaries that are depicted herein are the property of their respective owners. PerkinElmer reserves the right to change this document at any time without notice and disclaims liability for editorial, pictorial or typographical errors.

008493\_01